

SFP Managed Switch Eco Quick Start Guide

Provides (20) Gigabit Ethernet SFP, (4) Gigabit Ethernet Combo RJ-45/SFP, and (4) 1G/10G SFP+ connections.

This manual contains information for firmware version 1.59.



Customer Support Information

Order toll-free in the U.S.: Call 877-877-BBOX (outside U.S. call 724-746-5500)
FREE technical support 24 hours a day, 7 days a week: Call 724-746-5500 or fax 724-746-0746
Mailing address: Black Box Corporation, 1000 Park Drive, Lawrence, PA 15055-1018
Web site: www.blackbox.com • E-mail: info@blackbox.com

Trademarks Used in this Manual/About this Manual

Trademarks Used in this Manual

Black Box and the Double Diamond logo are registered trademarks of BB Technologies, Inc.

Any other trademarks mentioned in this manual are acknowledged to be the property of the trademark owners.

About this Manual

This manual gives specific information on how to operate and use the management functions of the switch. The manual is intended for use by network administrators who are responsible for operating and maintaining network equipment; consequently, it assumes a basic working knowledge of general switch functions, Internet Protocol (IP), and Simple Network Management Protocol (SNMP).

Conventions

The following conventions are used throughout this guide to show information:

NOTE: Emphasizes important information or calls your attention to related features or instructions.

WARNING: Alerts you to a potential hazard that could cause personal injury.

CAUTION: Alerts you to a potential hazard that could cause loss of data, or damage the system or equipment.

Related Publications

For specific information on how to operate and use the management functions of the switch, visit www.blackbox.com and enter LGB5128A in the search bar, then download the user's manual, or download the user's manual from ftp://ftp.blackbox.com/anonymous/manuals/L/LGB5128A_USER_rev1.pdf.

For information about the command-line interface (CLI), visit www.blackbox.com and enter LGB5128A in the search bar, then download the CLI guide, or download the CLI guide from ftp://ftp.blackbox.com/anonymous/manuals/L/LGB5128A_USER_rev1.pdf.

Cable Types

You may use unshielded twisted-pair (UTP) for RJ-45 connections —Category 3 or better for 10-Mbps connections; Category 5 or better for 100-Mbps connections; Category 5, 5e, or 6 for 1000-Mbps connections. For fiber optic connections, you may use 50-/125- or 62.5-/125-micron multimode fiber or 9-/125-micron single-mode fiber.

We're here to help! If you have any questions about your application or our products, contact Black Box Tech Support at **724-746-5500** or go to **blackbox.com** and click on "Talk to Black Box." You'll be live with one of our technical experts in less than 60 seconds.

Federal Communications Commission and Industry Canada Radio Frequency Interference Statements

This equipment generates, uses, and can radiate radio-frequency energy, and if not installed and used properly, that is, in strict accordance with the manufacturer’s instructions, may cause interference to radio communication. It has been tested and found to comply with the limits for a Class A computing device in accordance with the specifications in Subpart B of Part 15 of FCC rules, which are designed to provide reasonable protection against such interference when the equipment is operated in a commercial environment. Operation of this equipment in a residential area is likely to cause interference, in which case the user at his own expense will be required to take whatever measures may be necessary to correct the interference.

Changes or modifications not expressly approved by the party responsible for compliance could void the user’s authority to operate the equipment.

This digital apparatus does not exceed the Class A limits for radio noise emission from digital apparatus set out in the Radio Interference Regulation of Industry Canada.

Le présent appareil numérique n’émet pas de bruits radioélectriques dépassant les limites applicables aux appareils numériques de la classe A prescrites dans le Règlement sur le brouillage radioélectrique publié par Industrie Canada.

CE Mark

Declaration of Conformance for EMI and Safety (EEC)

This equipment has been tested and found to comply with the protection requirements of European Emission Standard EN55022/ EN61000-3 and the Generic European Immunity Standard EN55024.

EMC

EN55022(2006)+A1:2007/CISPR 22:2006+A1:2006	Class A 4K V CD, 8KV, AD
Throughput	130.9 Mpps
Flow control	Full-duplex: IEEE 802.3x; Half-duplex: Backpressure
EC61000-4-2 (2001)	3 V/m
IEC61000-4-3 (2002)	1 KV (power line), 0.5KV – (signal line)
IEC61000-4-4 (2004)	Line to Line: 1KV, Line to Earth: 2KV
IEC61000-4-5 (2001)	130 dBuV (3V) Level 2
IEC61000-4-6 (2003)	1 A/m
IEC61000-4-8 (2001)	Voltage dips: >95%, 0.5 period, 30%, 25 periods
IEC61000-4-11(2001)	Voltage interruptions: >95%, 250 periods

Safety Instructions

Safety Instructions

CAUTION: Circuit devices are sensitive to static electricity, which can damage their delicate electronics. Dry weather conditions or walking across a carpeted floor may cause you to acquire a static electrical charge.

To protect your device, always:

- Touch the metal chassis of your computer to ground the static electrical charge before you pick up the circuit device.
- Pick up the device by holding it on the left and right edges only.
- If you need to connect this device with outdoor devices, then you must add an arrester on the cable between the outdoor device and this device.

NOTE: The switch is an indoor device; if it will be used in outdoor environment or connects with some outdoor device, use a lightning arrester to protect the switch.

WARNING:

- *Do not demolish the product. If damage is caused by self-demolition, you will be charged a fee for repair.*
- *Do not place the product outdoors or in a sandstorm.*
- *Before installation, make sure the input power supply and product specifications are compatible with each other.*
- *To reduce the risk of electric shock, disconnect all AC or DC power cords and cables to completely remove power from the unit.*
- *Before importing/exporting a configuration, make sure the firmware version is the same.*
- *After a firmware upgrade, the switch will replace the configuration automatically with the latest firmware version.*

Instrucciones de Seguridad (Normas Oficiales Mexicanas Electrical Safety Statement)

1. Todas las instrucciones de seguridad y operación deberán ser leídas antes de que el aparato eléctrico sea operado.
2. Las instrucciones de seguridad y operación deberán ser guardadas para referencia futura.
3. Todas las advertencias en el aparato eléctrico y en sus instrucciones de operación deben ser respetadas.
4. Todas las instrucciones de operación y uso deben ser seguidas.
5. El aparato eléctrico no deberá ser usado cerca del agua—por ejemplo, cerca de la tina de baño, lavabo, sótano mojado o cerca de una alberca, etc.
6. El aparato eléctrico debe ser usado únicamente con carritos o pedestales que sean recomendados por el fabricante.
7. El aparato eléctrico debe ser montado a la pared o al techo sólo como sea recomendado por el fabricante.
8. Servicio—El usuario no debe intentar dar servicio al equipo eléctrico más allá a lo descrito en las instrucciones de operación. Todo otro servicio deberá ser referido a personal de servicio calificado.
9. El aparato eléctrico debe ser situado de tal manera que su posición no interfiera su uso. La colocación del aparato eléctrico sobre una cama, sofá, alfombra o superficie similar puede bloquea la ventilación, no se debe colocar en libreros o gabinetes que impidan el flujo de aire por los orificios de ventilación.
10. El equipo eléctrico debe ser situado fuera del alcance de fuentes de calor como radiadores, registros de calor, estufas u otros aparatos (incluyendo amplificadores) que producen calor.
11. El aparato eléctrico deberá ser conectado a una fuente de poder sólo del tipo descrito en el instructivo de operación, o como se indique en el aparato.
12. Precaución debe ser tomada de tal manera que la tierra física y la polarización del equipo no sea eliminada.
13. Los cables de la fuente de poder deben ser guiados de tal manera que no sean pisados ni pellizcados por objetos colocados sobre o contra ellos, poniendo particular atención a los contactos y receptáculos donde salen del aparato.
14. El equipo eléctrico debe ser limpiado únicamente de acuerdo a las recomendaciones del fabricante.
15. En caso de existir, una antena externa deberá ser localizada lejos de las líneas de energía.
16. El cable de corriente deberá ser desconectado del cuando el equipo no sea usado por un largo periodo de tiempo.
17. Cuidado debe ser tomado de tal manera que objetos líquidos no sean derramados sobre la cubierta u orificios de ventilación.
18. Servicio por personal calificado deberá ser provisto cuando:
 - A: El cable de poder o el contacto ha sido dañado; u
 - B: Objetos han caído o líquido ha sido derramado dentro del aparato; o
 - C: El aparato ha sido expuesto a la lluvia; o
 - D: El aparato parece no operar normalmente o muestra un cambio en su desempeño; o
 - E: El aparato ha sido tirado o su cubierta ha sido dañada.

Table of Contents

Table of Contents

1. Specifications.....	7
2. Overview	9
2.1 Introduction.....	9
2.2 What's Included	9
2.3 Front and Side Panels of the Switch	9
2.4 Switch Architecture	10
2.5 Network Management Options.....	10
2.6 Operation of Web-based Management	10
3. Hardware Description.....	11
3.1 1000BASE-T Ports	11
3.2 SFP and SFP+ Transceiver Slots	11
3.3 Port and System Status LEDs	11
3.4 Power Supply Sockets.....	12
4. Installing the Switch	13
4.1 Selecting a Site.....	13
4.2 Ethernet Cabling.....	13
4.3 Equipment Checklist.....	14
4.4 Mounting	14
4.4.1 Rackmounting	14
4.4.2 Desktop or Shelf Mounting.....	16
4.5 Installing an Optional SFP Transceiver	16
4.6 Connecting to an AC Power Source.....	17
4.7 Connecting to a DC Power Source.....	18
4.8 Wiring Map for Serial Cable	18
4.9 Fiber Optic SFP+ Devices	18
4.10 Connectivity Rules	19
4.11 1000BASE-T Cable Requirements.....	20
4.12 1000-Mbps Gigabit Ethernet Collision Domain.....	20

1. Specifications

1.1 Physical Characteristics

Aggregate Bandwidth	128 Gbps for the LGB5128A switch
Buffer Architecture	1392 KB on-chip frame buffer
Network Interface	Ports 1-20: SFP connector, 10BASE-T: RJ-45 (100-ohm, UTP cable; Category 3 or better) 100BASE-TX: RJ-45 (100-ohm, UTP cable; Category 5 or better) 1000BASE-T: RJ-45 (100-ohm, UTP, or STP cable; Category 5, 5e, or 6); Maximum Cable Length: 328 ft (100 m) Ports 21-24: RJ-45 connector/(100/1000M) SFP; Ports 25-28: 1G/10G SFP+
Switching Database	32K MAC address entries
Connectors	(20) 10/100/1000Mbps SFP; (4) Gigabit Ethernet Combo Port TP/ (100/1000M) SFP; (4) (1G/10G) SFP+
Environment	Temperature Tolerance: Operating: 32 to 140° F (0 to 60° C); Humidity Tolerance: Operating: 5% to 90% (non-condensing)
Power	Power A: 100 to 240 VAC, 50–60 Hz; Power B: -36 VDC to -48 VDC Power Supply: Power A: Output: 12 VDC, 70 Watts Power B: Output: 12 VDC, 70 Watts Power Consumption: 55 Watts maximum
Dimensions	1.7"H x 17.4"W x 8.3"D (4.4 x 44.2 x 21.1 cm)
Weight	6.83 lb. (3.1 kg)

1.2 Switch Features

Forwarding Mode	Store-and-forward
Throughput	130.9 Mpps
Flow control	Full-duplex: IEEE 802.3x; Half-duplex: Backpressure

Chapter 1: Specifications

1.3 Management Features

Approvals	Emissions: EN55022 (CISPR 22) Class A EN 61000-3; FCC Class A; CE Mark; Immunity: EN 61000-4-2/3/4/5/6/8/11; EN 55024
In-Band Management	SSH/SSL, Telnet, SNMP, or HTTP
Software Loading	HTTP, TFTP in-band, Console out-of-band
Standards	IEEE 802.3 => 10BASE-T Ethernet (Twisted-pair Copper) IEEE 802.3u => 100BASE-TX Ethernet (Twisted-pair Copper) IEEE 802.3ab => 1000BASE-TX Ethernet (Twisted-pair Copper) IEEE 802.3z => 1000BASE-X Ethernet IEEE 802.3ae => 10GBASE-SR/ER Ethernet IEEE 802.3x => Flow Control Capability ANSI/IEEE 802.3 => Auto-negotiation IEEE 802.1Q => VLAN IEEE 802.1p => Class of Service IEEE 802.1X => Access Control IEEE 802.1D => Spanning Tree IEEE 802.1w => Rapid Spanning Tree IEEE 802.1s => Multiple Spanning Tree IEEE 802.3ad => Link Aggregation Control Protocol (LACP) IEEE 802.1AB => Link Layer Discovery Protocol (LLDP)

2. Overview

2.1 Introduction

The Gigabit SFP Managed Switch Eco provides a reliable infrastructure for your small business or enterprise network. The switch's intelligent features enable you to improve the availability of your critical business applications, protect your sensitive information, and optimize your network bandwidth to deliver information and applications more effectively. Plus, the switch is easy to set up and use.

The Gigabit SFP Managed Switch Eco has (24) Gigabit Ethernet ports and (4) 10G Ethernet ports. The switch supports advanced security management capabilities and network features for data, voice, security, and wireless technologies. It's easy to deploy and configure, providing stable and quality performance network services.

2.2 What's Included

Your package should contain the following items. If anything is missing or damaged, contact Black Box Technical Support at 724-746-5500 or info@blackbox.com.

- Gigabit SFP Managed Switch Eco
- (4) adhesive rubber feet
- Mounting accessory for 19" rack shelf
- (1) RS-232 DB9-to-DB9 cable
- (1) AC power cord

To download the user manual, visit www.blackbox.com and enter LGB5128A in the search bar, then download the user's manual, or download the user's manual from ftp://ftp.blackbox.com/anonymous/manuals/L/LGB5128A_USER_rev1.pdf.

To download the command-line interface (CLI) guide, go to ftp://ftp.blackbox.com/anonymous/manuals/L/LGB5128A_CLI_rev1.pdf.

2.3 Front and Side Panels of the Switch

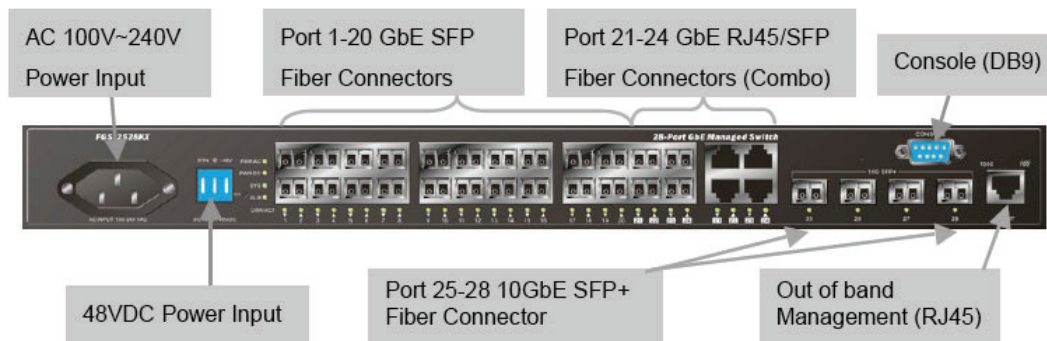

Figure 2-1. Front of the switch.

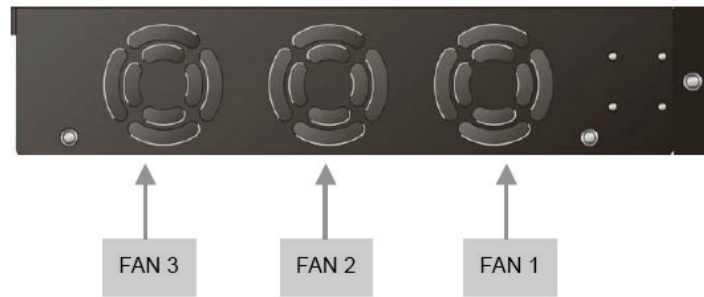

Figure 2-2. Side panel of the switch (fan location).

2.4 Switch Architecture

The switch transports multiple packets at wire-speed and low latency on all ports simultaneously. It operates in full-duplex mode on all ports to effectively double the bandwidth of each connection.

This switch uses store-and-forward technology to ensure maximum data integrity. With this technology, the entire packet must be received into a buffer and checked for validity before being forwarded. This prevents errors from being propagated throughout the network.

2.5 Network Management Options

You can manage the switch over the network with a Web browser or Telnet application. Its built-in network management agent helps you manage NMP or RMON (Groups 1, 2, 3, 9) protocols.

NOTE: For a detailed description of the management features, refer to the user's manual. To download the user manual, visit www.blackbox.com and enter LGB5128A in the search bar, then download the user's manual, or download the user's manual from ftp://ftp.blackbox.com/anonymous/manuals/L/LGB5128A_USER_rev1.pdf.

2.6 Operation of Web-based Management

The default values of the LGB5128A are listed below:

IP address: 192.168.1.1

Subnet mask: 255.255.255.0

Default gateway: 192.168.1.254

User name: admin

Password: (blank)

First, configure your device's Ethernet interface to be in the same subnet as the LGB5128A switch. Then, you can browse to the LGB5128A. For example, if you type <http://192.168.1.1>, it will show the login screen and ask you to input a username and password to login and authorize access to the switch.

The default username is "admin," and the default password is blank. The first time you access the switch, enter the default username. At the password prompt, simply press the enter key. Next, click the "Login" button.

3. Hardware Description

3.1 1000BASE-T Ports

The switch has 10/100/1000BASE-T RJ-45 ports. All RJ-45 ports support automatic MDI/MDI-X operation, auto-negotiation, and IEEE 802.3x auto-negotiation of flow control, so the switch automatically selects the optimum data rate and transmission.

3.2 SFP Transceiver Slots

The switch supports Small Form Factor Pluggable (SFP) transceiver slots on ports 1 to 24. It also supports four combo interface (RJ-45/SFP) ports 21 to 24, which can each be configured as RJ-45 or SFP ports. In the default configuration, if an SFP transceiver (part numbers LFP401–LFP404, LFP411–LFP416) is installed in a slot and has a valid link on the port, the associated RJ-45 port is disabled. Ports 25 to 28 support 10GbE SFP+ transceiver (part numbers LSP421 and LSP422) slots, a high performance interface for backbone uplink.

3.3 Port and System Status LEDs

The switch includes a display panel for system and port LEDs that simplify installation and network troubleshooting. The LEDs, located on the left hand side of the front panel for easy viewing, are shown below and described in the following table.

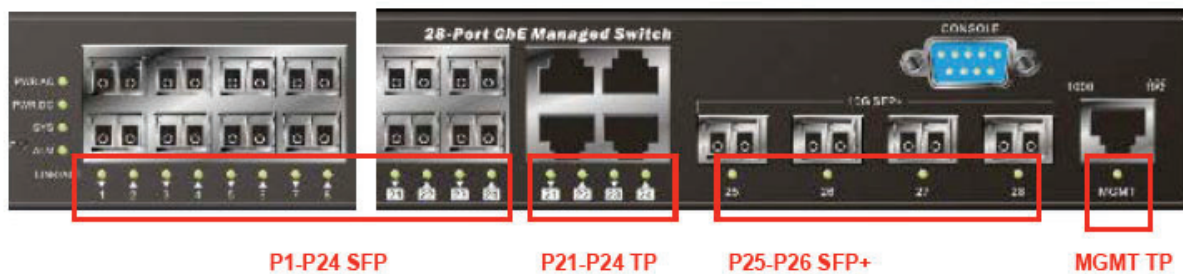

Figure 3-1. Port status LEDs on the front panel.

Table 3-1. Port Status LEDs

LED	Color	Status
P1–P24 SFP Link/Act/Speed	Green/Amber	Lights when fiber connection with the remote device is good. Blinks when any traffic is present. Lights Green when linking to 1000 Mbps. Lights Amber when linking to 100 Mbps.
P21–P24 TP Link/Act/Speed	Green/Amber	Lights Green when TP link on 10-/1000-Mbps speed. Lights Amber when TP link on 100-Mbps speed. Blinks when any traffic is present.
P25–P26 SFP+ Link/Act/Speed	Green/Amber	Lights Green when SFP+ link on 10-Gbps speed. Lights Amber when SFP+ link on 1-Gbps speed. Blinks when any traffic is present.
MGMT TP Link/Act/Speed	Green/Amber	Lights Green when TP link on 10-/1000-Mbps speed. Lights Amber when TP link on 100-Mbps speed. Blinks when any traffic is present.



Figure 3-2. System Status LEDs on the front panel.

Table 3-2. System Status LEDs

LED	Color	Status
PWR AC	Green	Lights when power is on.
PWR DC	Green	Lights when power is on.
SYS	Green/ Amber	Blinks when system is booting. Lights when system is coming up.
ALARM	Red	Normally off; only system error will turn the light on.

3.4 Power Supply Sockets

There are dual power inputs on the front panel of the switch for power redundancy. The switch has a 100 to 240 VAC power socket for AC power Input and a -36 to -48 VDC power input via terminal block.



100 to 240-VAC Power Input -36 VDC to -48 VDC Power Input

Figure 3-3. Power supply connectors.

4. Installing the Switch

4.1 Selecting a Site

NOTE: The switch can be mounted in a standard 19-inch equipment rack (via the included rackmount kit). Follow the guidelines below when choosing a location.

The site should:

- Be located at the center of all the devices you want to link and near a power outlet.
- Be able to maintain its temperature within 32 to 140° F (0 to 60° C) and its humidity within 10% to 90%, non-condensing.
- Be accessible for installing cabling and maintaining the devices.
- Allow the status LEDs to be clearly visible.

NOTES:

Make sure the twisted-pair Ethernet cable is always routed away from power lines, radios, transmitters, or any other electrical interference.

Make sure that the switch is connected to a separate grounded power outlet.

4.2 Ethernet Cabling

To ensure proper operation when installing the switch into a network, make sure that the current cables are suitable for 100BASE-TX or 1000BASE-T operation. Check the following criteria against the current installation of your network:

- Cable type: Unshielded twisted pair (UTP) or shielded twisted pair (STP) cable with RJ-45 connectors. We recommend Category 5 or Category 5e with a maximum length of 328 feet (100 meters) for 100BASE-TX, and Category 5e or 6 with a maximum length of 328 feet (100 meters) for 1000BASE-T.
- Protection from radio frequency interference emissions.
- Electrical surge suppression.
- Separation of electrical wires and data based network wiring.
- Safe connections with no damaged cables, connectors, or shields.

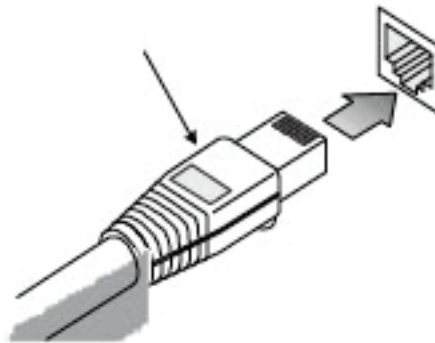

Figure 4-1. RJ-45 connections.



Figure 4-2. SFP transceiver.

4.3 Equipment Checklist

After unpacking this switch, please check the contents to be sure you have received all the components (listed below and in Section 2.2). Then, before beginning the installation, be sure you have all other necessary installation equipment.

- Gigabit SFP Managed Switch Eco
- (4) adhesive rubber feet
- Mounting accessory for 19" rack shelf
- (1) RS-232 DB9-to-DB9 cable
- (1) AC power cord

To download the user manual, visit www.blackbox.com and enter LGB5128A in the search bar, then download the user's manual, or download the user's manual from ftp://ftp.blackbox.com/anonymous/manuals/L/LGB5128A_USER_rev1.pdf.

WARNING: The SFP/SFP+ modules are Class 1 laser devices. Avoid direct eye exposure to the beam coming from the transmit port.

4.4 Mounting

The switch can be mounted in a standard 19-inch equipment rack or on a desktop or shelf. Mounting instructions for each type of site follows.

4.4.1 Rackmounting

Before rackmounting the switch, please pay attention to the following factors:

- Temperature: Since the temperature within a rack assembly may be higher than the ambient room temperature, check that the rack environment temperature is within the specified operating temperature range 32 to 140° F (0 to 60 °C).
- Mechanical Loading: Do not place any equipment on top of a rackmounted unit.
- Circuit Overloading: Be sure that the supply circuit to the rack assembly is not overloaded.
- Grounding: Rackmounted equipment should be properly grounded.

To rackmount Devices: (Optional)

Step 1. Attach the brackets to the device using the screws provided in the mounting accessory.

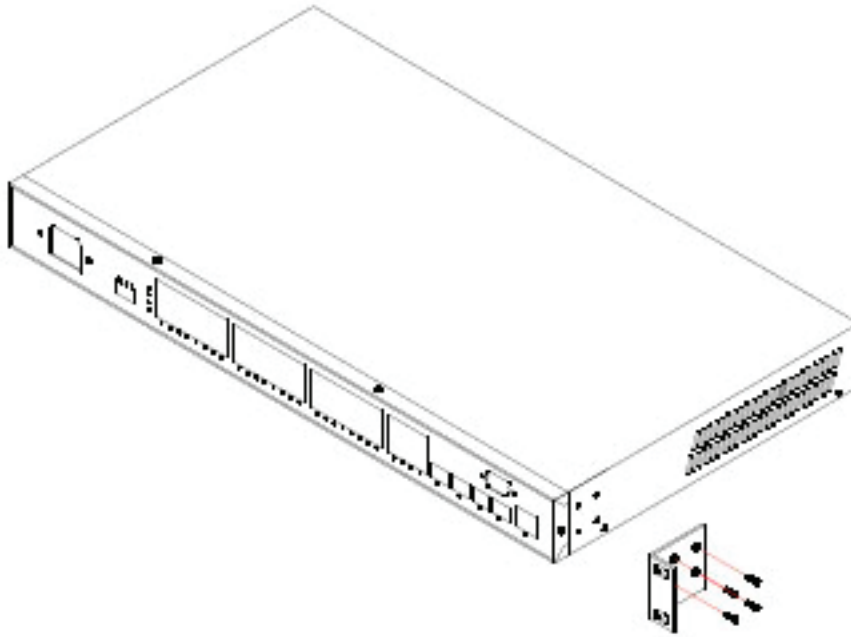

Figure 4-3. Attaching the brackets.

Step 2. Mount the device in the rack (via the rackmount kit), using four rackmounting screws (not provided). Be sure to secure the lower rackmounting screws first to prevent the brackets from bending from the weight of the switch.

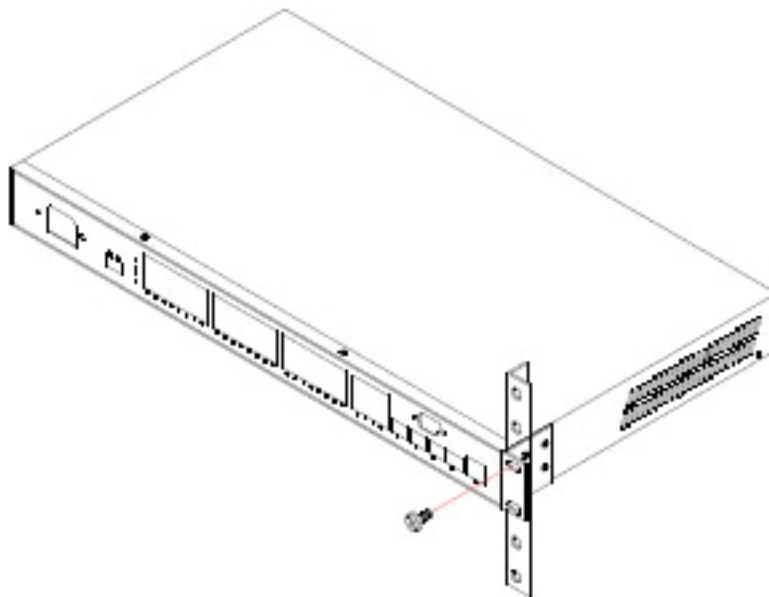

Figure 4-3. Installing the switch in a rack.

Chapter 4: Installing the Switch

Step 3. If installing a single switch only, go to Section 4.6 or 4.7 in this manual.

Step 4. If installing multiple switches, mount them in the rack, one below the other, in any order.

4.4.2 Desktop or Shelf Mounting

Step 1. Attach the four adhesive rubber feet to the bottom of the first switch.

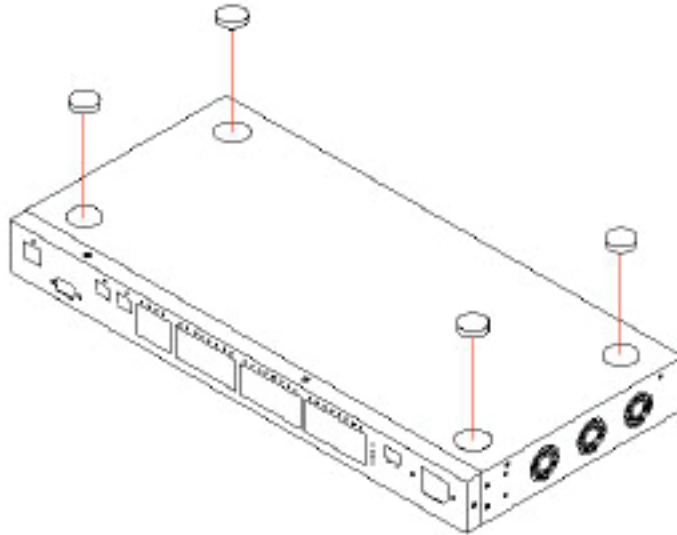

Figure 4-5. Attaching the adhesive rubber feet.

Step 2. Set the device on a flat surface near an AC power source, with at least two inches of space on all sides for proper airflow.

Step 3. If installing a single switch only, go to Section 4.6 or 4.7 in this manual.

Step 4. If installing multiple switches, attach four adhesive feet to each one. Place each device squarely on top of the one below, in any order.

4.5 Installing an Optional SFP Transceiver

You can install or remove an SFP/SFP+ module from an SFP/SFP+ slot without having to power off the switch. Use only compatible SFPs (see Table 4-1).

Table 4-1. Compatible Black Box SFPs.

Table 4-1. Compatible Black Box SFPs.

Part Number	Product Name
LFP401–LFP404	155-Mbps Extended Diagnostic SFP
LFP411–LFP414, LFP416*	1250-Mbps Extended Diagnostic SFP
LSP421–LSP422	10GBASE-SR SFP, 10GBASE-LR SFP

*Supports LFP416 with auto mode of link speed on Ports 1–20 and does not support LFP415.

NOTES:

The SFP slots are shared with the four 10/100/1000BASE-T RJ-45 ports. If an SFP is installed in a slot, the associated RJ-45 port is disabled and cannot be used.

NOTES (Continued):

The SFP ports operate only at full duplex. Half-duplex operation is not supported.

Ensure the network cable is NOT connected when you install or remove an SFP module.

CAUTION: Use only supported SFP modules with your switch (see Table 4-1).



Figure 4-6. Inserting an SFP transceiver into a slot.

To install an SFP transceiver, do the following:

Step 1. Consider network and cabling requirements to select an appropriate SFP transceiver type.

Step 2. Insert the transceiver with the optical connector facing outward and the slot connector facing down.

NOTE: SFP transceivers are keyed so they can only be installed in one orientation.

Step 3. Slide the SFP transceiver into the slot until it clicks into place.

NOTE: SFP transceivers are not provided in the switch package.

4.6 Connecting to an AC Power Source

You can plug or remove an AC power cord through the AC socket from the AC power source.



Figure 4-7. Inserting the AC power cord into the AC socket to power on this switch.

Step 1. Insert the AC power cord directly into the AC socket located at the front of the switch.

Step 2. Plug the other end of the power cord into an AC power source.

Step 3. Check the front-panel LEDs as the device is powered on to be sure the POWER LED is lit. If not, check that the power

Chapter 4: Installing the Switch

cable is correctly plugged in.

4.7 Connecting to a DC Power Source

You can plug or remove a DC power cable through the DC terminal block from an external 48-VDC power source.



Figure 4-6. Inserting the DC power cable into the DC terminal block to power on this switch.

Step 1. Insert the DC cable plug directly into the DC terminal block located at the front of the switch.

Step 2. Plug the other end of the cable into an external DC power source.

Step 3. Check the front-panel LEDs as the device is powered on to be sure the POWER LED is lit. If not, check that the power cable is correctly plugged in.

4.8 Wiring Map for Serial Cable

Table 4-2. Serial cable wiring.

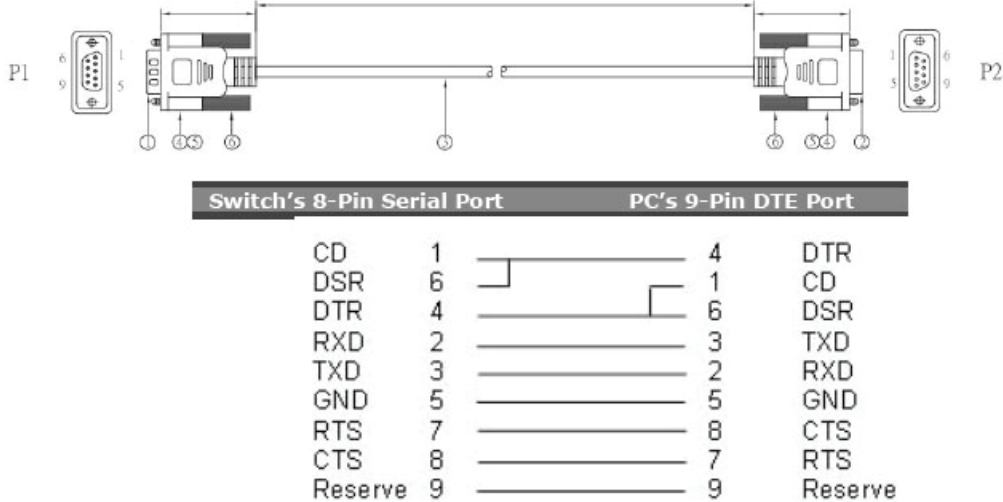

NOTE: The switch does not support crossover cable for the console port.

4.9 Fiber Optic SFP+ Devices

An optional 10G SFP+ transceiver can be used for a backbone connection between switches, or for connecting to a high-speed server.

Each single-mode fiber port requires 9-/125-micron single-mode fiber optic cable with an LC connector at both ends. Each multimode fiber optic port requires 50-/125- or 62.5-/125-micron multimode fiber optic cabling with an LC connector at both ends.

WARNING: This switch uses lasers to transmit signals over fiber optic cable. Never look directly at a transmit port when it is

powered on.

WARNING: When selecting a fiber SFP device, make sure that it can function at a temperature that is not less than the recommended maximum operational temperature of the product. You must also use an approved Laser SFP transceiver.

Step 1. Remove and keep the LC port's rubber plug. When not connected to a fiber cable, replace the rubber plug to protect the optics.

Step 2. Check that the fiber terminators are clean. You can clean the cable plugs by wiping them gently with a clean tissue or cotton ball moistened with a little ethanol. Dirty fiber terminators on fiber optic cables will impair the quality of the light transmitted through the cable and lead to degraded performance on the port.

Step 3. Connect one end of the cable to the LC port on the switch and the other end to the LC port on the other device. Since LC connectors are keyed, the cable can be attached in only one orientation.

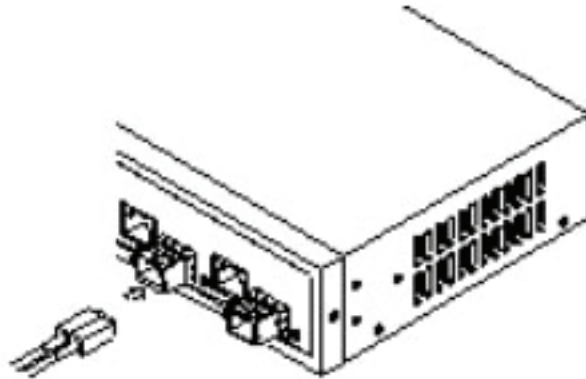

Figure 4-8. Making fiber port connections.

Step 4. As a connection is made, check the Link LED on the switch corresponding to the port to be sure that the connection is valid.

The fiber optic ports operate at 1 Gbps. The maximum length for fiber optic cable operating at Gigabit speed will depend on the fiber type as listed in Section 4.12, 1000-Mbps Gigabit Ethernet Collision Domain.

4.10 Connectivity Rules

NOTE: When adding hubs to your network, switches break up the path for connected devices into separate collision domains, so you don't include the switch or connected cabling in your calculations for cascade length involving other devices.

Chapter 4: Installing the Switch

4.11 1000BASE-T Cable Requirements

All Category 5 UTP cables that are used for 100BASE-TX connections should also work for 1000BASE-T, providing that all four wire pairs are connected. However, we recommend that for all critical connections, or any new cable installations, you use Category 5e or Category 6 cable. The Category 5e and 6 specifications include test parameters that are only recommendations for Category 5. Therefore, the first step in preparing existing Category 5 cabling for running 1000BASE-T is a simple test of the cable installation to be sure that it complies with the IEEE 802.3-2005 standards.

4.12 1000-Mbps Gigabit Ethernet Collision Domain

Table 4-3. 1000-Mbps Gigabit Ethernet collision domain.

Maximum 1000BASE-T Gigabit Ethernet cable domain.			
Cable Type	Maximum Cable Length	Connector	
Category 5, 5e, or 6 100-ohm UTP or STP	328 ft. (100 m)	RJ-45	
Maximum 1000BASE-SX Gigabit fiber cable length.			
Fiber Size	Fiber Bandwidth	Maximum Cable Length	Connector
62.5-/125-micron multimode fiber	160 MHz/km	722 ft. (220 m)	LC
	200 MHz/km	902 ft. (275 m)	
50-/125-micron multimode fiber	400 MHz/km	1641 ft. (500 m)	LC
	500 MHz/km	1805 ft. (550 m)	
Maximum 1000BASE-LX/LHX/XD/ZX Gigabit fiber cable length.			
Fiber Size	Fiber Bandwidth	Maximum Cable Length	Connector
9-/125-micron single-mode fiber 1310 nm	N/A	6.2 miles (10 km)	LC
9-/125-micron single-mode fiber 1550 nm	N/A	18.64 miles (30 km)	LC
		31.06 miles (50 km)	
Maximum 1000BASE-LX Single Fiber Gigabit fiber cable length.			
Fiber Size	Fiber Bandwidth	Maximum Cable Length	Connector
Single-mode TX: 1310 nm RX: 1550 nm	N/A	12.42 miles (20 km)	BIDI LC
Single-mode TX: 1550 nm RX: 1310nm	N/A	12.42 miles (20 km)	BIDI LC
100-Mbps Fast Ethernet collision domain.			
Cable Type	Maximum Cable Length	Connector	
Category 5, 5e or 6 100-ohm UTP or STP	328 ft. (100 m)	RJ-45	

Black Box Tech Support: FREE! Live. 24/7.

Tech support the
way it should be.



Great tech support is just 60 seconds away at 724-746-5500 or blackbox.com.



About Black Box

Black Box provides an extensive range of networking and infrastructure products. You'll find everything from cabinets and racks and power and surge protection products to media converters and Ethernet switches all supported by free, live 24/7 Tech support available in 60 seconds or less.

© Copyright 2013. Black Box Corporation. All rights reserved. Black Box® and the Double Diamond logo are registered trademarks of BB Technologies, Inc. Any third-party trademarks appearing in this manual are acknowledged to be the property of their respective owners.

LGB5128A Quick Start Guide, version 2

724-746-5500 | blackbox.com